



BRAVOSOLE / BRAVOSOLE DUPLEX

Automatic industrial softener for drinking and industrial water

Rev. 2 - 10/24



CHARACTERISTICS

One of the crucial problems in plumbing and heating systems and hot water production is the formation of limestone encrustations. Limescale deposits on pipes, boilers and water heaters, thus clogging them, reducing their efficiency, increasing energy costs and maintenance costs. Furthermore, limescale deposits on tanks and showers, sinks and taps, thus creating unsightly stains.

But that's not all: washing surfaces, dishes and clothing with hard water involves greater consumption of detergents and soaps. Furthermore, washing is not optimal as surfaces and dishes remain stained and clothes are less soft and pleasant to the touch.

Softening represents the solution for the prevention of limescale deposits.

Using a water softener means enjoying the following benefits:

- Savings on energy costs
- Reduction of costs for repairs and maintenance.
- Reduction of unsightly stains on taps and shower boxes, walls, etc.
- Reduction of encrustations on pipes, appliances and boilers
- Reduction in detergent consumption.

Furthermore, softened water has a healing effect on encrusted surfaces, thus eliminating, over time, the limestone concretions already present.

BravoSOLE is a double body water softener (column of resins and brine tank) designed to treat large flow rates with small dimensions. This makes it the ideal choice for centralized plumbing and heating systems in condominiums, accommodation facilities, communities, laundries and, more generally, in all those applications that require high hydraulic load peaks compared to average flow rates. BravoSOLE water softeners are completely automatic and independently manage the work and regeneration phases, thus combining a robust and compact body with intuitive and reliable operation.

The containment tank is made of S235JR steel finished according to the best anti-corrosion standards: preliminary internal and external sandblasting treatment at Sa2.5 grade, primer with zinc salts, followed by internal coating with epoxy resin suitable for food use and external painting with RAL 9010 white powder. Distribution is guaranteed by a central distributor in the upper part and a bottom or radial filter in the lower part. The tank is equipped with an upper sleeve for loading resins and a lower hatch with a diameter of 300 mm to facilitate loading and maintenance operations. The digital electronic control interface allows you to quickly view fundamental operating information such as: time of day and days until the next regeneration.

The volumetric version manages the residual softened



SOFTENING

water reserve, the total volume of treated water delivered and the instantaneous flow rate. All working data and service history are stored and can be recalled at any time for system analysis.

BravoSOLE water softeners are equipped with a backup battery for data storage in the event of a power failure. The control panel is equipped with #2 relay outputs for controlling external systems (i.e., dosing pumps, exchange solenoid valves, alarms, etc.). The duration of each of the 4 regeneration phases can be programmed individually, thus allowing you to optimize times and water and salt consumption.

Parameters to be treated	BravoSOLE
Turbidity	-
Flavors	-
Odors	-
Atrazine and the like	-
Tri+tetrachlorethylene	-
Iron	-
Manganese	-
Hardness	optimal

1+1 DUPLEX SOFTENER MANAGEMENT

The BRAVOSOLE line water softening systems are also managed in the double column version - Duplex, which guarantees the supply of softened water at any time. This is the ideal solution for industrial or process applications where there is a need to have softened water 24 hours a day.

The BravoSOLE DUPLEX water softener includes the supply of:

- n. 2 complete tanks
- n. 2 brine tanks; n. 2 control valves; N. 1 three-way valve for managing the two columns; n. 1 pulse meter for managing the volume operation of the water softener

Optional:

- n. 1 Geko resin disinfection dosing stations



indicative image

TECHNICAL DATA

Code		AB0004004	AB0004005	AB0004006	AB0004007	AB0004008
Code Duplex		AB0004014	AB0004015	AB0004016	AB0004017	AB0004018
Model		BRAVOSOLE 325	BRAVOSOLE 400	BRAVOSOLE 500	BRAVOSOLE 600	BRAVOSOLE 700
Fittings	R	2" F	2" F	2" F	2" F	2" F
Nominal flow rate, 0 °fr*	m ³ /h	12	14	16	18	20
Short peak range, 0 °fr**	m ³ /h	18	20	22	25	28
Resin volume	Lt	325	400	500	600	700
Cyclic capacity	m ³ x°fr	1950	2400	3000	3600	4200
Salt consumption for regeneration	kg	49	60	75	90	105
Brine tank volume	Lt	1000	1000	1500	1500	1500
Salt brine tank contents	Kg	900	900	1350	1350	1350
Number of regenerations	N.	15	12	15	12	10
Min./max. water temperature	°C	+5 / +40				
Min./max. ambient temperature	°C	+5 / +40				
Min./max. water pressure	bar	2,5 / 6				
Power supply	V-HZ	230 / 50				
Valve protection degree	--	IP54				

Key: *Pressure drop: ΔP=approximately 0.6 bar - **Pressure drop: ΔP=approximately 1.0 bar

Notes: empty weight not including brine tank.

FILTER MATERIAL FILLING TABLE - Single column

Model	u.m.	HCR-S/S resin	u.m.	Quartzite, grain size 2.0 - 3.0
BRAVOSOLE 325	Lt	325	Kg	75
BRAVOSOLE 400	Lt	400	Kg	75
BRAVOSOLE 500	Lt	500	Kg	100
BRAVOSOLE 600	Lt	600	Kg	100
BRAVOSOLE 700	Lt	700	Kg	100

FILTER MATERIAL FILLING TABLE - Duplex version

Model	u.m.	HCR-S/S resin	u.m.	Quartzite, grain size 2.0 - 3.0
BRAVOSOLE 325	Lt	650	Kg	150
BRAVOSOLE 400	Lt	800	Kg	150
BRAVOSOLE 500	Lt	1000	Kg	200
BRAVOSOLE 600	Lt	1200	Kg	200
BRAVOSOLE 700	Lt	1400	Kg	200



OVERALL DIMENSIONS Referred to a single column

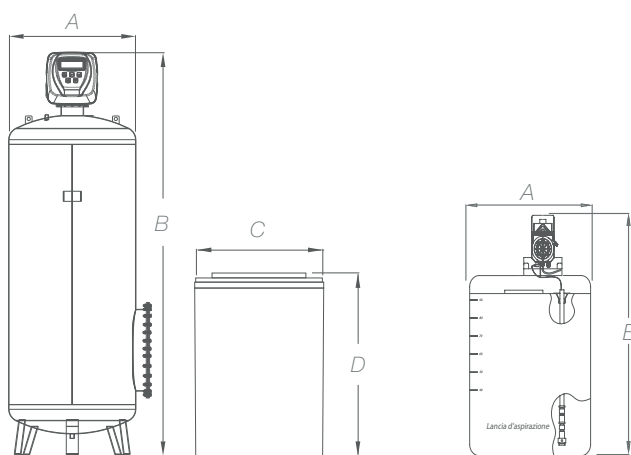

Code	A	B	C	D	E	Empty weight
	mm	mm	mm	mm	mm	Kg
AB0004004	750	2324	1080	1460	2200	140
AB0004005	750	2324	1080	1460	2200	140
AB0004006	900	2423	1240	1275	2300	173
AB0004007	900	2423	1240	1275	2300	173
AB0004008	950	2489	1240	1275	2335	183

Overall dimensions may be subject to changes without notice



EQUIPMENT AND SUPPLY SPECIFICATIONS

BravoSOLE is supplied complete with brine tank, without filter material (to be ordered separately) and without optional accessories; instruction manual for use - maintenance in Italian (including declaration of conformity).

Shipping managed on one or more pallets.



OPTIONAL ACCESSORIES

• 1" 1/4 CONNECTOR BOOST VALVE



The boost valve is used in systems that can work with significant variations in flow rate; In case of high water demand (simultaneous use) the bypass circuit is activated ensuring the required flow rate.

The adjustment is performed after installation, manually adjusting the compression of the valve's internal spring, using the appropriate upper knob; In this way the intervention pressure of the valve is adjusted which, in case of boost, opens the shutter allowing the passage of water; Body in CW617N brass - EPDM gaskets and seals -

TECHNICAL DATA:

IN connections: 1"1/4 F - OUT connections: 1"1/4 M - Calibration range: 1/6 bar - Max. flow rate: 10 mc/h - Max. operating pressure: 10 bar - Min-max temperature: 0-110 bar

COD. 31015900

• HARDNESS CALIBRATION VALVE 1"1/2 CONNECTIONS



The hardness calibration valve is a balancing valve that allows you to adjust the hardness level of the water coming out of the softener; in the case of water intended for human consumption, it is always advisable not to supply completely softened water but mixed at least at 10 °f. The adjustment is carried out by manually acting on the valve knob that controls the movement of a shutter that regulates the passage of water. CW602N brass body - EPDM gaskets and seals

TECHNICAL DATA:

IN/OUT connections: 1"1/2 F - Max. flow rate: 13.7 mc/h - Max. operating pressure: 16 bar - Max. temperature: 120 bar

COD. 31015904

• GEKO DISINFECTION RESIN DOSING STATION



Complete dosing station for resin disinfection equipped with:

- 25 lt tank with black HDPE containment tank
- suction lance and level probe
- digital dosing pump suitable for dosing disinfectant chemicals, complete with 6x4 PVC crystal suction pipe and 6x4 PE delivery pipe

The TCK pump of the dosing station must be connected directly to the softener control valve with the product injection point in the brine tank.

TCK pump dosing min/max lt/h: 4-8

TCK pump pulse frequency/minute: 160

TCK pump gasket kit: PVDF

Min/max pressure bar: 2-12

Electrical power supply: 230 V - 50/60 Hz - Cable with Schuko plug

Min/max ambient temperature °C: 5-40

Each softener column requires a dosing station

COD. SD993200

• PRODUCT TO BE DOSED - FERROCID® 8592



Product to be used with dosing station GEKO for resin disinfection

Ferrocid® 8592 is an aqueous solution of sodium hypochlorite suitable for use in water intended for human consumption. Ferrocid® 8592 can be added to water to facilitate the elimination of iron, manganese and ammonia from water. Thanks to its oxidizing capacity, it is also able to destroy the organic substance present in the water and is at the same time active against a wide range of algae and microorganisms present in tanks and pipes, also helping to prevent their formation. Ferrocid® 8592 is dangerous for transport

and, therefore, falls within the ADR requirements. Drinking use. - Can of Kg 20

COD. PC074

• FILTER MATERIAL

• Strong, food-grade cationic resin with a sulfonated polystyrene gel structure. High chemical-physical stability, high sphericity and resistance to friction guarantee resistance, longevity and low pressure drops.



• High purity siliceous quartzite (SiO₂ content greater than 95%) suitable for food use. Quartzite is used as a support layer underneath the cationic resins.



FILTER MATERIAL - Drinking use -

Packaging: 25 kg bags - 900/1000 kg Big Bags

COD. 48100032

Strong cationic resin

COD. 48100006

Quartzite 2,0-3,0

• HARDNESS ANALYSIS KIT



Total water hardness analysis kit, colorimetric.

The analysis is expressed in French degrees (°F);

the kit includes a test tube, indicator, titrant and instructions. You will be able to evaluate whether to install a softener or if the assembled system is working.

COD. 48105001

• SALT



Claramat is specifically designed for use in water softeners for private, condominium and industrial use.

Thanks to its extremely high purity (99.8%), Claramat does not dirty the cylinder and brine tank of water softeners, always guaranteeing

the best performance without variations in the quality of the water supplied.

Its recrystallized formulation in tablets significantly increases its duration over time, while maintaining stable purification values.

Claramat water softener salt complies with the EN 973 type A regulation.

Drinking use - 25 kg bags

Cod. 48100007

• START-UP AND FINAL TESTING

Upon request, Water Treatment Industry can provide the start-up and testing service carried out by a specialized technician.

Please contact us for information on the scheduled periodic maintenance service.

COD. 84022106 BRAVOSOLE 325 - 400 - 500
Equipment filling service
quote daily cost

COD. 84022106 BRAVOSOLE 600 - 700
Equipment filling service
quote daily cost

For the BRAVOSOLE DUPLEX version, the cost of the equipment filling service must be doubled

COD. 84022111 BRAVOSOLE
equipment initial start-up and testing service
quote daily cost

COD. 84022112 BRAVOSOLE DUPLEX
equipment initial start-up and testing service
quote daily cost

The services do not include travel expenses related to the kilometeric cost of the car according to ACI tables, as well as motorway travel. Services refer to the national territory (excluding islands)

REFERENCE STANDARDS

D.M. n. 174/2004: Regulation concerning materials and objects that can be used in fixed systems for the collection, treatment, supply and distribution of water intended for human consumption.

Direttiva 2014/30/UE: concerning the approximation of the laws of the Member States relating to electromagnetic compatibility.

Direttiva 2014/35/UE: concerning the approximation of the laws of the Member States relating to electrical equipment intended for use within certain voltage limits.

Art. 4 Par. 3 Of Directive 2014/68/EU (PED).

UNI EN 13445-3 Pressure vessels not exposed to flame - Part 3: Design Input

PRECAUTIONS AND WARNINGS

Attention! If this equipment is used for the treatment of water intended for human consumption, it requires regular periodic maintenance in order to guarantee the drinkability requirements of the treated drinking water and the maintenance of the improvements as declared by the manufacturer.

Protect from frost and bad weather, thus avoiding contact with

solvents and chemical products in general. Water softening reduces the concentration of calcium and magnesium ions in the water and increases the concentration of sodium ions. These parameters are regulated by current legislation. It is necessary not to excessively soften the water so as not to exceed the limit value of 200 mg/l of sodium established by current legislation. When softening water intended for human consumption, it is therefore recommended to always maintain a residual hardness level of at least

10°f. Furthermore, the water subjected to softening can have aggressive characteristics towards the pipes and regulating bodies made of metallic material.

In the case of treatment of water intended for human consumption, it is therefore recommended to provide an AcquaSIL® dosing device downstream of the BravoSOLE softeners.



MAINTENANCE

Periodically check the correct operation of the equipment. Ordinary operation of the equipment requires periodic regeneration. Make sure that there is always a sufficient amount of salt in the brine tank (the water level in the tank must always be lower than the salt level). If there is a periodic cleaning and sanitization plan for the system, it is also necessary to include the equipment. To ensure correct management of the equipment, it is advisable to carry out at least two checks per year. Respect all the instructions given in the Use and Maintenance Manual.



INSTALLATION

Installation must be carried out exclusively by qualified personnel and in full compliance with local regulations. BravoSOLE water softeners are made to treat water intended for human consumption. Do not supply BravoSOLE water softeners with water that does not meet the requirements established by current legislation.

The installation must be carried out in hygienically suitable places, provided with the services necessary for the correct operation of the equipment, protected from direct exposure to the sun, frost, bad weather, away from detergents, solvents and chemical products in general. Supply the equipment with water within the specified temperature and pressure limits. Install the water softener upstream of the equipment/system to be protected.

The equipment must be equipped with an adequate bypass system that allows it to be excluded if necessary. It is also necessary to provide sampling points upstream and downstream of the equipment to be able to verify its operation. Provide an adequate system for collecting and/or disposing of brine and spent regeneration water. Check local provisions for the disposal of brine and regeneration water.

Before carrying out the installation, see the use and maintenance manual.

INDICATIVE INSTALLATION DIAGRAMS

Single column version

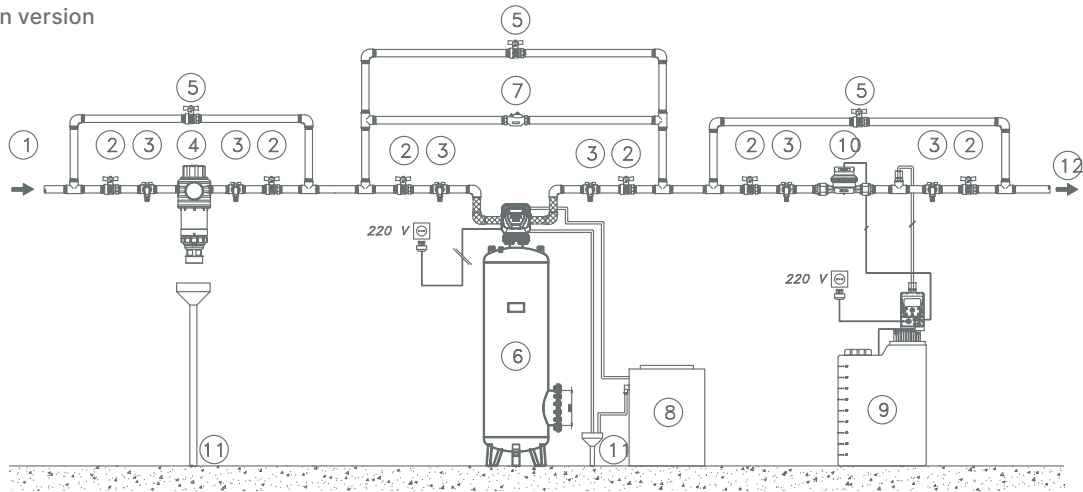

1. Raw water inlet; 2. Shut-off valve; 3. Sample tap; 4. Protection filter; 5. By-pass valve;
6. BravoSOLE water softener; 7. Multifunction valve; 8. Brine tank; 9. AcquaSIL dosing station; 10. Pulse launcher meter;
11. Drain; 12. Treated water outlet.

Double column version (Duplex)

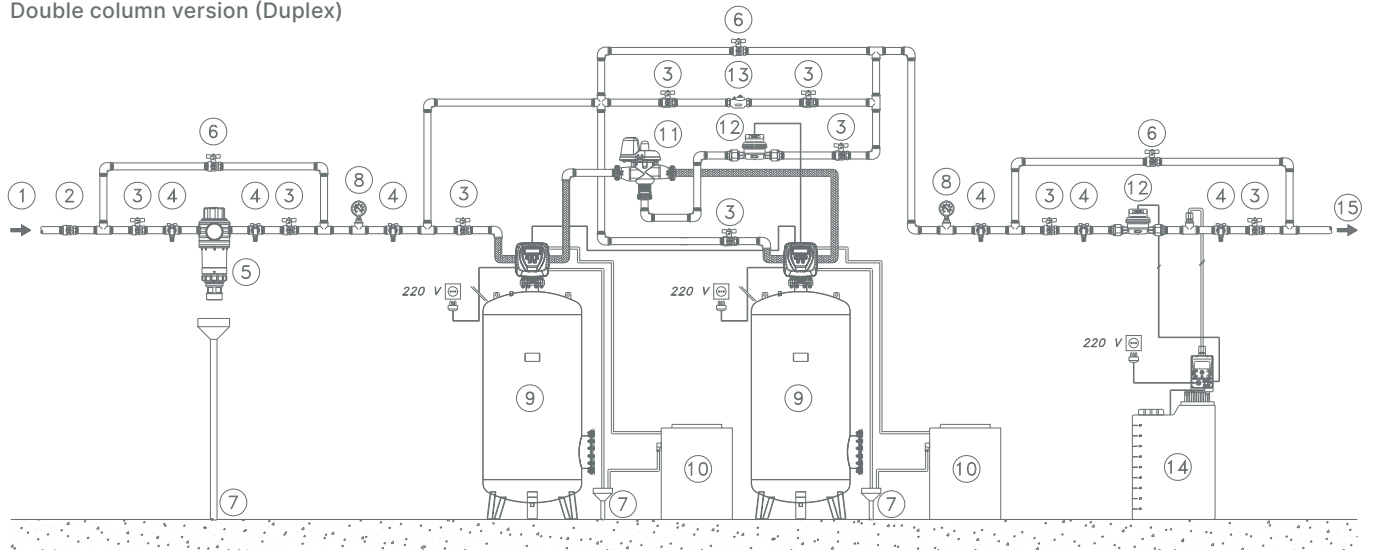

1. Raw water inlet; 2. Non return valve; 3. Shut-off valve; 4. Sample tap; 5. Protection filter;
6. By-pass valve; 7. Drain; 8. Gauge; 9. BravoSOLE water softener; 10. Brine tank; 11. Alternating valve;
12. Pulse launcher meter; 13. Boost valve - hardness calibrator; 14. Dosing station; 15. Treated water outlet.

SPARE PARTS

Spare parts for the equipment are available on request in the dedicated price list.

AVERAGE DELIVERY TIMES

2-3 weeks

GENERAL EXCLUSIONS

- Filling the filter material tank
- Equipment start-up and final testing
- Special dedicated packaging, where required - wooden crates
- Lifting and handling means
- Hydraulic and electrical connections to our plant and to our utilities
- Masonry, carpentry and foundation works
- Chemical analyses
- Structural calculations
- Anything not expressly mentioned in the offer